

●Features:

- Common Cathode Structure
- Low Power Loss and High Efficiency
- Low Forward Voltage Drop
- High Surge Capability

●Application:

- High Frequency Switch
- Free Wheeling, and Polarity Protection Applications

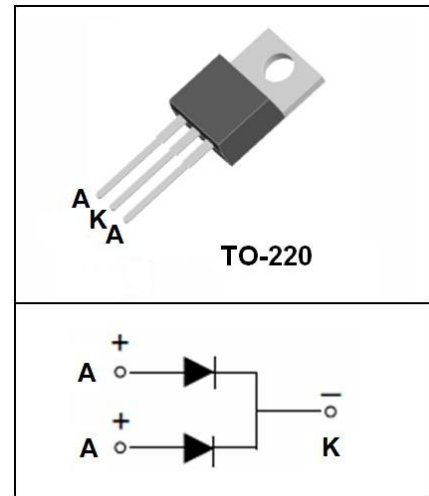

Absolute Maximum Ratings (T_c=25°C unless otherwise noted)

Symbol	Parameter	Value	Unit
V _{RRM}	Maximum Repetitive Reverse Voltage	100	V
V _R	Maximum DC Reverse Voltage	100	V
I _{F(AV)}	Average Rectified Forward Current, T _c =120°C	5(Per Leg) 10(Per Device)	A
I _{FSM}	Peak Forward Surge Current, 8.3ms Half Sine wave	100	A
T _j	Operating Junction Temperature	150	°C
T _{stg}	Storage Temperature Range	-55 to +150	°C

Thermal Characteristics (T_c=25°C unless otherwise noted)

Symbol	Parameter	Max	Unit
R _{θJC}	Thermal Resistance, Junction to Case Per Leg	2.5	°C /W
R _{θJA}	Thermal Resistance, Junction to Ambient Per Leg	105	°C /W

Electrical Characteristics (T_c=25°C unless otherwise noted)

Symbol	Parameter	Test Conditions	Min	Max	Unit
V _{RRM}	Maximum Repetitive Reverse Voltage	I _R =100μA	100		V
I _R	Reverse Current	V _R =100V T _c =25°C V _R =100V T _c =125°C		0.1 5	mA
V _F	Forward Voltage	I _F =5A T _c =25°C I _F =5A T _c =125°C I _F =10A T _c =25°C I _F =10A T _c =125°C		0.86 0.76 0.96 0.86	V

Typical Performance Characteristics

Figure 1. Forward Current Characteristics

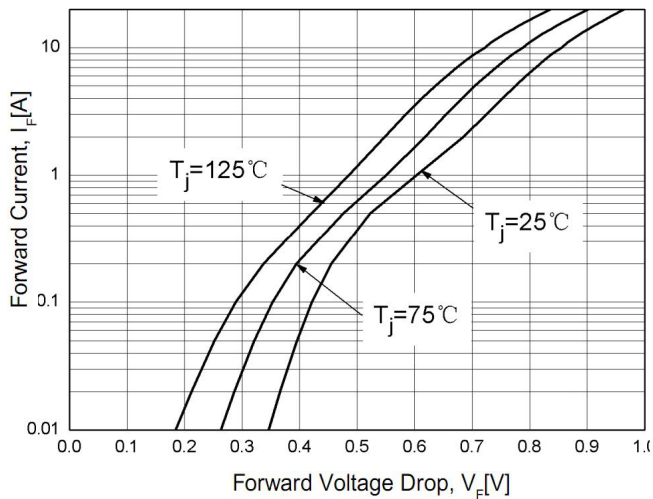

Figure 2. Reverse Leakage Current

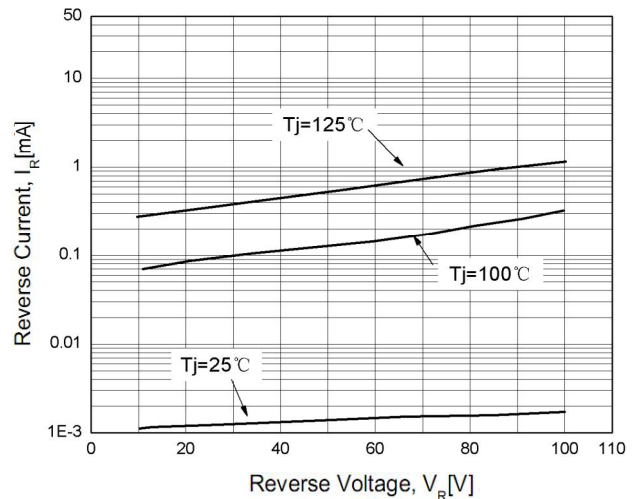

Figure 3. Junction Capacitance

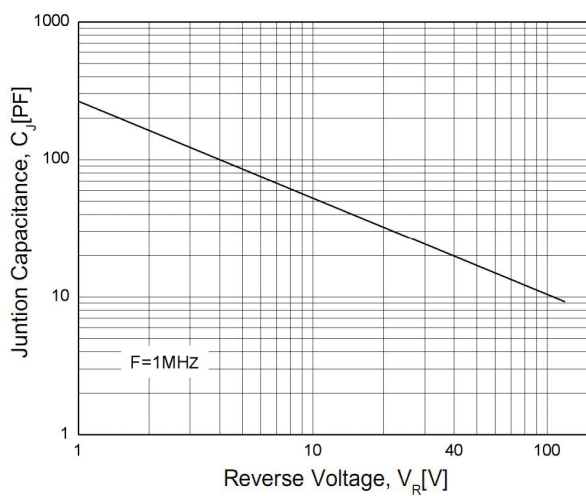
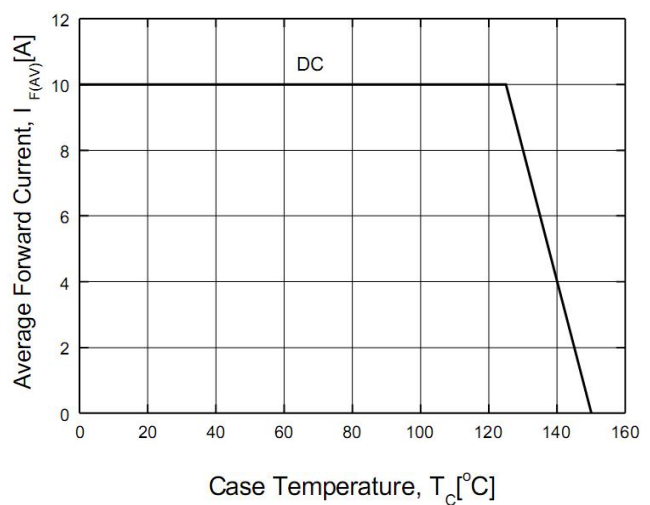

Figure 4. Power Derating



TO-220 MECHANICAL DATA

UNIT: mm

SYMBOL	min	nom	max	SYMBOL	min	nom	max
A	4.00		4.80	E	9.70		10.70
B	1.15		1.45	e		2.54	
B1	0.90		1.40	F	1.10		1.40
b1	0.65		0.95	L	12.50		14.50
c	0.30		0.50	L1	2.90	3.40	3.90
D	14.40		16.40	Q	2.50		3.10
D1	5.90		6.90	Q1	2.00		3.00
				ϕP	3.60		4.00

